

# UNM STL 780-15-500 C H846001

## Product Information Sheet



Technical data	H846001
Suction capacity	780 l/min
Eff. Delivery quantity	640 l/min
Start-up- / switch-off pressure	13/15 bar
Cylinder / Stages	2/2
Tank volume	500 l
Voltage	400 Volt/50 Hz
Drive power	5.5 kW
Speed	830 min <sup>-1</sup>
Noise	80 dB(A)
Dimensions (WxDxH)	1950 x 625 x 1380 mm
Air outlet	¾"
Weight	308 kg

## Product Description

- Stationary compressor with star-delta switch with integral motor protection and low voltage circuit breaker which ensure a high degree of operating safety
- Compressor for work up to 15 bar
- Smooth running belt driven 2-cylinder unit with 2-stage compression
- Suitable for many jobs in the professional field
- Applications:  
Expansion of compressed air systems,  
Increase reliability
- Highest quality of installed components

# UNM STL 780-15-500 C H846001

## Product Information Sheet



### Quiet running and optimal cooling

due to the new wedge-driven compressor unit with optimal cooling air flow and improved delivery performance

### Reduced noise level

Less noise from new unit

### Compressor with low speed of rotation

Reduced vibrations preserve the compressor components

### Long service life

guaranteed by 15-year warranty against rust-through of vessel

### Space-saving design

Small footprints thanks to optimal arrangement of the components

### Motionless standing position

Standard features include: anti vibration rubber feet

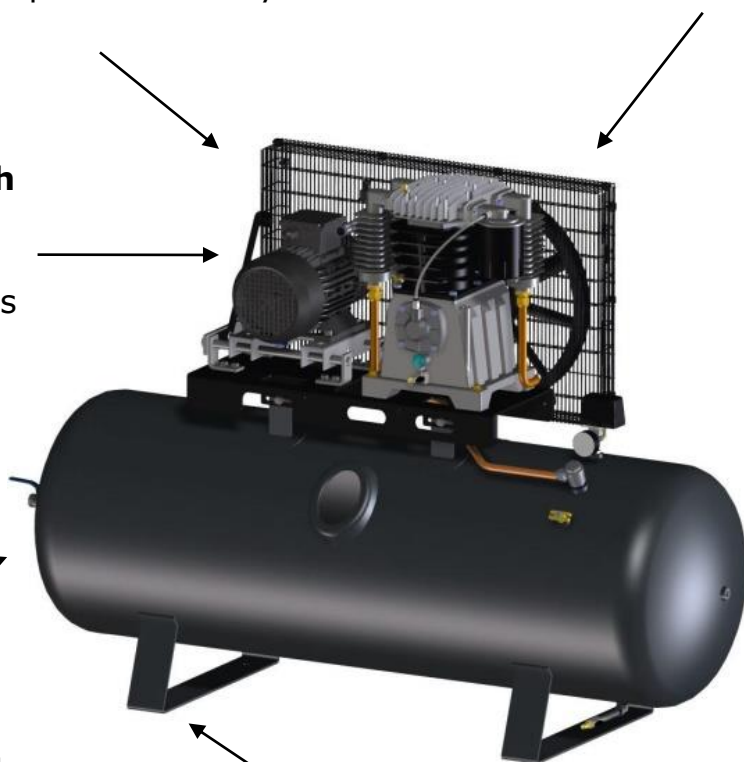

## Further information

Complete equipment

Pressure switch, motor protection, safety and check valve, container pressure gauge, unloaded start

Scope of delivery

Instruction manual

Warranty

- 12 months for professional industrial use  
- 24 months for private use only