

1) TOOL TYPE - GERAETETYP - DESCRIZIONE MACCHINA - TYPE D'OUTIL - TIPO DE MAQUINA
 cod. 11785 F47C B7/G-65



2) TOOL CHARACTERISTICS
 SPEZIFICATION DES GERAETES
 CARATTERISTICHE TECNICHE
 CARACTÉRISTIQUES DE L'OUTIL
 CARACTERÍSTICAS DE LA MAQUINA

HEIGHT HOEHE ALTEZZA HAUTEUR ALTURA	WIDTH BREITE LARGHEZZA LARGEUR ANCHURA	LENGTH LAENGE LUNGHEZZA LONGUEUR LONGITUD	WEIGHT GEWICHT PESO POIDS PESO
in. 13.78 mm. 350	in. 3.74 mm. 95	in. 15.35 mm. 390	lbs. 6.34 kg. 2.880
MIN-MAX WORKING PRESSURE MIN-MAX ARBEITSDRUCK MIN-MAX PRESSIONE DI ESERCIZIO MIN-MAX PRESSION DE TRAVAIL MIN-MAX PRESSION DE TRABAJO		70 / 120 psi 5 / 8 BAR	
AIR CONSUMPTION PER CYCLE LUFTVERBRAUCH PRO NAGELUNG CONSUMO ARIA PER COLPO CONSUMATION DE L'AIRE PAR COUP CONSUMO DE AIRE CADA DISPARO		PERFORMANCES AT 90 psi (0.62 MPa) PRESTAZIONI A 6.2 BAR (0.62 MPa) 0.051 SCF 1.45 L.	
LUBRICANT SCHMIEROEL LUBRIFICANTE LUBRIFIANT LUBRIFICANTE		AEROSPACE LUBRICANTS TRIBOLUBE 12	

* ACTUATION SYSTEM * AUSLÖSEART * ATTUAZIONE * MISE EN ŒUVRE * ACTUACIÓN	4 (SAFETY : CT)
--	-----------------

* SEE INSTRUCTION MANUAL - SIEHE BETRIEBSANLEITUNG - VEDI MANUALE - VOIR MODE D'EMPLOI - VER EL MANUAL

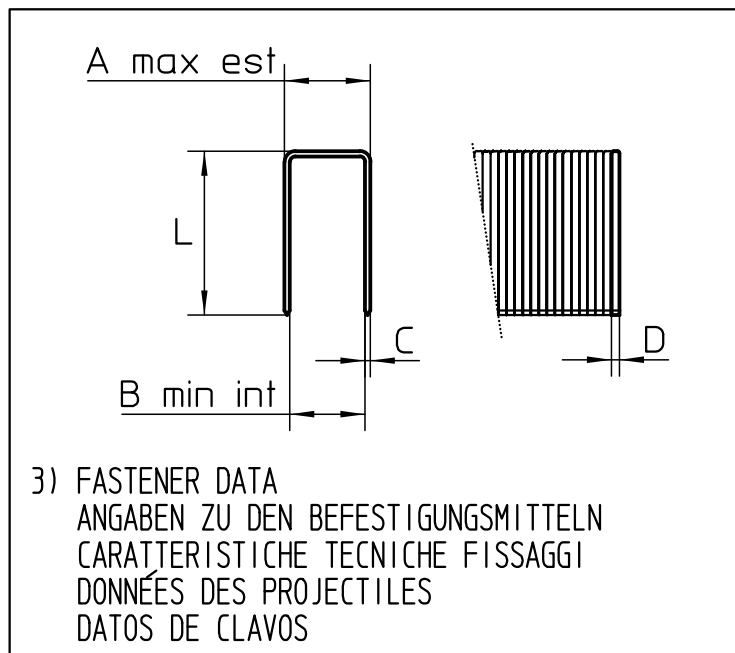

3) FASTENER DATA
 ANGABEN ZU DEN BEFESTIGUNGSMITTELN
 CARATTERISTICHE TECNICHE FISSAGGI
 DONNÉES DES PROJECTILES
 DATOS DE CLAVOS

A) OUTSIDE CROWN AUSSEN RUECKEN LARGHEZZA EST. COURONNE EXT. CORONA EXT.	MAX	in. 0.444 mm. 11.30
B) INSIDE CROWN INNEN RUECKEN LARGHEZZA INT. COURONNE INT. CORONA INT.	MIN	in. 0.29 mm. 7.60
CxD) WIRE DRAHT FILO FIL ALAMBRE		in. 0.055 x 0.062 mm. 1.40 x 1.60
L) LENGTH LAENGE LUNGHEZZA LONGUEUR LONGITUD	MIN-MAX	in. 1' - 2 1/2' mm. 25 - 65
MAGAZINE CAPACITY MAGAZIN CAPAZITAET CAPACITA' CARICATORE CAPACITE' CHARGEUR CAPACIDAD CARGADOR		128 staples

* LOADING	BOTTOM LOADING
* LADEN	SIDE LOADING
* CARICAMENTO	● TOP LOADING
* CHARGER	COIL
* CARGA	OTHER

NOISE CHARACTERISTICS GERÄUSCH - EMISSION DATEN CARATTERISTICHE RUMOROSITA' CARACTÉRISTIQUES ACOUSTIQUE CARACTERÍSTICAS DE RUIDO	EN 12549+A1:2008	$L_{WA,1s}$, : 104.90 dB(A) - $K_{WA,1s}$, 2.5
	EN ISO 4871:2009	$L_{pA,1s}$, : 92.40 dB(A) - $K_{pA,1s}$, 2.5

VIBRATION VALUE VIBRATIONSWERT VALORE DI VIBRAZIONE VALEUR DE VIBRATION VALOR DE VIBRACIÓN	UNI ISO/TS 8662-11	m/s ² 4.24
--	-----------------------	-----------------------