

1) TOOL TYPE - GERAETETYP - DESCRIZIONE MACCHINA - TYPE D'OUTIL - TIPO DE MAQUINA

cod.11753 58A RHN 20-90C SCR

3) FASTENER DATA
 ANGABEN ZU DEN BEFESTIGUNGSMITTELN
 CARATTERISTICHE TECNICHE FISSAGGI
 DONNÉES DES PROJECTILES
 DATOS DE CLAVOS

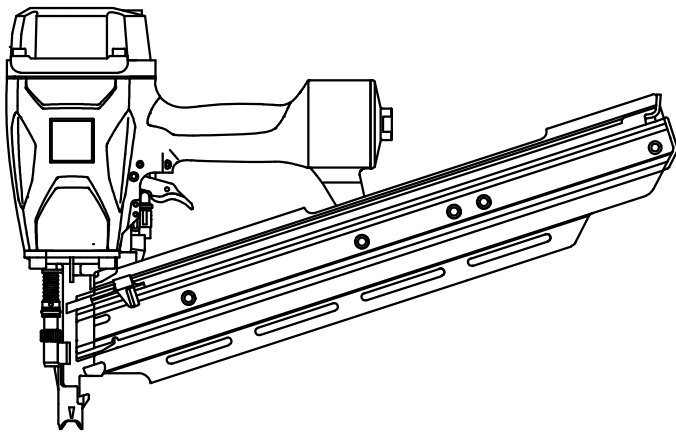

2) TOOL CHARACTERISTICS
 SPEZIFICATION DES GERAETES
 CARATTERISTICHE TECNICHE
 CARACTÉRISTIQUES DE L'OUTIL
 CARACTERÍSTICAS DE LA MAQUINA

HEIGHT - HAUTEUR HOEHE - ALTURA ALTEZZA	WIDTH - LARGEUR BREITE - ANCHURA LARGHEZZA	LENGTH - LONGUEUR LAENGE - LONGITUD LUNGHEZZA	WEIGHT - POIDS GEWICHT - PESO PESO
in. 13.78 mm. 350	in. 5.39 mm. 137	in. 21.2 mm. 540	lbs. 7.84 kg. 3.560
MIN-MAX WORKING PRESSURE MIN-MAX ARBEITSDRUCK MIN-MAX PRESSIONE DI ESERCIZIO MIN-MAX PRESSION DE TRAVAIL MIN-MAX PRESION DE TRABAJO		70 / 120 psi 5 / 8 BAR	
AIR CONSUMPTION PER CYCLE LUFTVERBRAUCH PRO NAGELUNG CONSUMO ARIA PER COLPO CONSUMATION DE L'AIRE PAR COUP CONSUMO DE AIRE CADA DISPARO		PERFORMANCES AT 90 psi (0.62 MPa) PRESTAZIONI A 6.2 BAR (0.62 MPa) 0.066 SCF 1.86 L.	
LUBRICANT SCHMIEROEL LUBRIFICANTE LUBRIFIANT LUBRIFICANTE		AEROSPACE LUBRICANTS TRIBOLUBE 12	

* ACTUATION SYSTEM * AUSLÖSEART * ATTUAZIONE * MISE EN ŒUVRE * ACTUACION	3/4 SAFETY FS/CT	* LOADING * LADEN * CARICAM. * CHARGER * CARGA	BOTTOM LOADING ● SIDE LOADING ● TOP LOADING COIL OTHER
--	------------------------	--	--

* SEE INSTRUCTION MANUAL - SIEHE BETRIEBSANLEITUNG
 - VEDI MANUALE - VOIR MODE D'EMPLOI - VER EL MANUAL

NOISE CHARACTERISTICS GERÄUSCH - EMISSION DATEN CARATTERISTICHE RUMOROSITA' CARACTÉRISTIQUES ACOUSTIQUE CARACTERÍSTICAS DE RUIDO	EN 12549+A1:2008 EN ISO 4871:2009
$L_{WA,1s}$: 98.38 dB(A) - $K_{WA,1s}$, 2.5	
$L_{pA,1s}$: 93.00 dB(A) - $K_{pA,1s}$, 2.5	

VIBRATION VALUE VIBRATIONSWERT VALORE DI VIBRAZIONE VALEUR DE VIBRATION VALOR DE VIBRACIÓN	UNI ISO/TS 8662-11 m/s ² 3.98
--	--

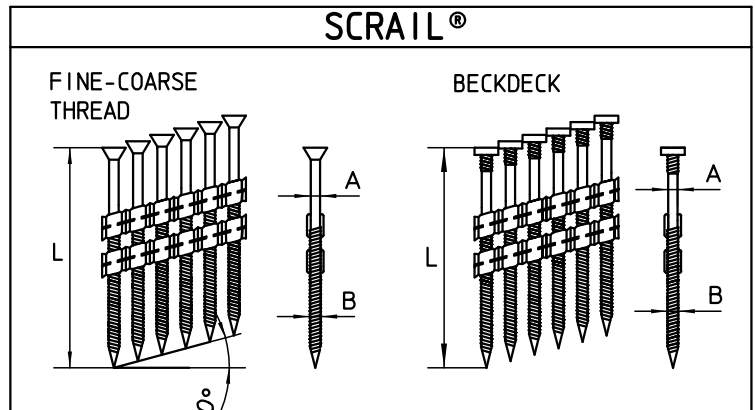

		FINE		COARSE		BECKDECK	
		MIN	MAX	MIN	MAX	MIN	MAX
A-B) WIRE SCHAFT FILO ALAMBRE TIGE	in mm	.113-	.138	.113-	.134	.120-	.138
C) HEAD KOPF TESTA TETE CABEZA		STAR / TORX VERSA SQUARE PHILIPS POZI		STAR / TORX VERSA SQUARE PHILIPS POZI		SQUARE DRIVE	
L) LENGTH LAENGE LUNGHEZZA LONGEUR LONGITUD	in mm	2' - 3'		2' - 3'		2' - 2-9/16'	
MAGAZINE CAPACITY MAGAZIN CAPAZITAET CAPACITA' CARICATORE CAPACITE' CHARGEUR CAPACIDAD CARGADOR		62 SCRAIL®		62 SCRAIL®		62 SCRAIL®	

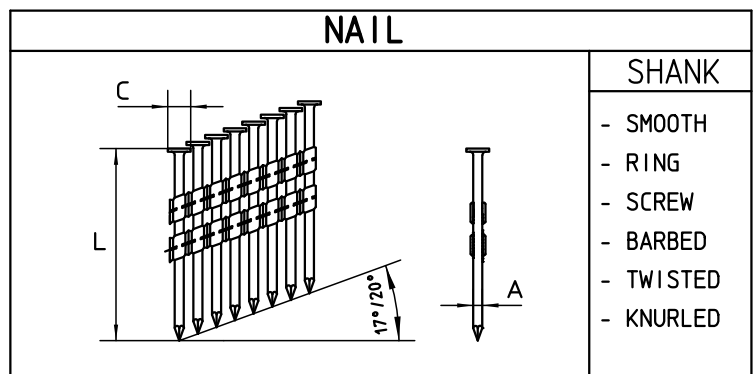

		MIN	MAX
A) WIRE - SCHAFT FILO - ALAMBRE TIGE	in mm	.114 -	.148
C) HEAD - KOPF TESTA - TETE CABEZA	in mm	0.275	7.0
L) LENGTH LAENGE LUNGHEZZA LONGEUR LONGITUD	in mm	2' - 3-1/2'	
MAGAZINE CAPACITY MAGAZIN CAPAZITAET CAPACITA' CARICATORE CAPACITE' CHARGEUR CAPACIDAD CARGADOR		62 NAILS	