

UNM STL 1000-10-270

1121570215 (No. old: H835000)

Product Information Sheet

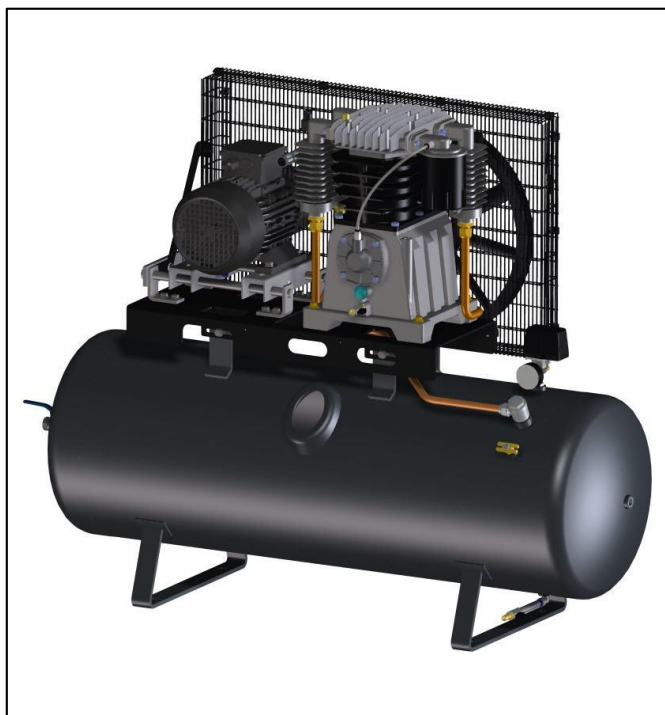

Technical data	1121570215
Suction capacity	1000 l/min
Eff. Delivery quantity	790 l/min
Start-up- / switch-off pressure	8/10 bar
Cylinder / Stages	2/2
Tank volume	270 l
Voltage	400 Volt/50 Hz
Drive power	5.5 kW
Speed	1260 min ⁻¹
Noise	82 dB(A)
Dimensions (WxDxH)	1620 x 555 x 1285 mm
Air outlet	¾"
Weight	238 kg

Product Description

- Stationary compressor
- Compressor for work up to 10 bar
- Smooth running belt driven 2-cylinder unit with 2-stage compression
- Suitable for many jobs in the professional field
- Applications:
Expansion of compressed air systems,
Increase reliability
- Highest quality of installed components

UNM STL 1000-10-270

1121570215 (No. old: H835000)

Product Information Sheet



Quiet running and optimal cooling

due to the new wedge-driven compressor unit with optimal cooling air flow and improved delivery performance

Reduced noise level

Less noise from new unit

Compressor with low speed of rotation

Reduced vibrations preserve the compressor components

Long service life

guaranteed by 15-year warranty against rust-through of vessel

Space-saving design

Small footprints thanks to optimal arrangement of the components

Motionless standing position

Standard features include: anti vibration rubber feet

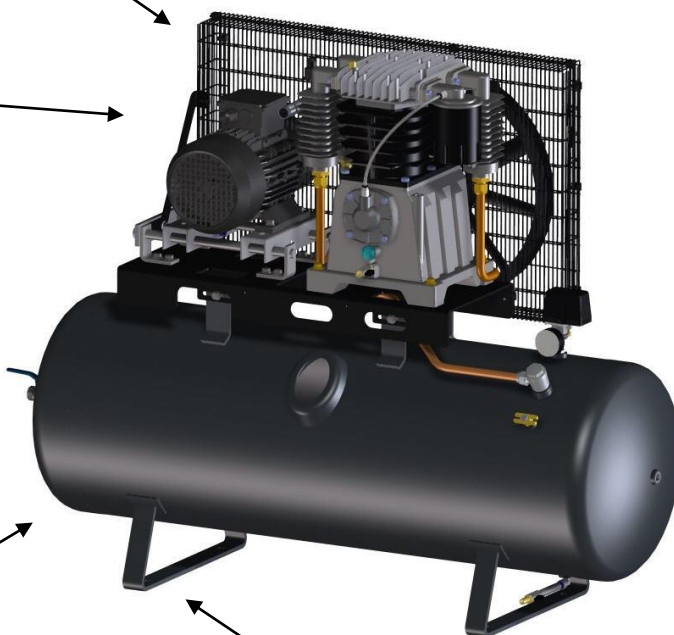

Further information

Complete equipment

Pressure switch, motor protection, safety and check valve, container pressure gauge, unloaded start

Scope of delivery

Instruction manual

Warranty

- 12 months for professional industrial use
- 24 months for private use only